

OWNER'S MANUAL 193111-038

Revised November 16, 2020

L ight

T ough

D ependable

BATTERY CHARGER

**IMPORTANT: Read this manual before installing,
operating, or servicing this product.**

**IMPORTANT: SAVE THIS SAFETY AND INSTRUCTION MANUAL.
IMMEDIATELY REPLACE WHEN WORN OR LOST.**

LTD Products
Prestolite Power
66 Industry Ct Suite F
Troy, Ohio
45373

DO NOT DESTROY

AMETEK/PRESTOLITE POWER , TROY, OHIO 45373-1099, U.S.A.

GENERAL SAFETY PRACTICES FOR ANY ELECTRICAL EQUIPMENT

1. READ THE SPECIFIC **SAFETY INSTRUCTIONS AND WARNINGS** CHAPTER OF THIS MANUAL BEFORE INSTALLING AND USING THE EQUIPMENT.
2. READ AND RETAIN THE OWNER'S MANUAL – All the safety and operating instructions should be read and understood before using the equipment.
3. FOLLOW INSTRUCTIONS – All installation, operating and maintenance instruction should be followed.
4. WATER AND MOISTURE – The equipment should not be used near water – for example, near a washbowl, steam cleaning equipment or in any wet or damp area.
5. VENTILATION – The equipment should be situated such that its location or position does not interfere with its required ventilation.
6. HEAT – The equipment should be situated away from heat sources such as radiators, heat registers, or any other equipment that produces heat.
7. POWER SOURCE – The equipment should be connected to a source of power only as described in the Owner's Manual.
8. GROUNDING – Precautions should be taken to insure the equipment grounding means is not defeated.
9. POWER CORD AND CHARGING CABLE PROTECTION – Power supply and charging cables should be routed to prevent them from being walked on, pinched by other equipment, or driven over.
10. CLEANING – Cleaning should only be performed as instructed in the Owner's Manual.
11. NON-USE PERIODS – The power cord should be unplugged from the outlet and the battery should be disconnected from the charger if the equipment is to be left unused for a long period of time.
12. OBJECT AND LIQUID ENTRY – Care should be taken so objects do not fall or liquids are not spilled into cabinet openings.
13. DAMAGE REQUIRING SERVICE – The equipment should be serviced by qualified service personnel when:
 - A. Power cord or plug, charging cables or connector have been damaged.
 - B. Objects have fallen into, or liquid has been spilled into the equipment.
 - C. The equipment has been dropped, or the cabinet damaged.
 - D. The equipment does not appear to operate normally or exhibits a marked change in performance.
14. REPLACEMENT PARTS – When replacement parts are needed, be sure only replacement parts specified by the manufacturer are used. Unauthorized substitutions may result in fire, electric shock, or other hazards.

**GENERAL SAFETY PRACTICE
FOR ANY ELECTRICAL EQUIPMENT**

Inside Front Cover

SAFETY INSTRUCTIONS AND WARNINGS	1
A. GENERAL	1-1
B. SHOCK PREVENTION	1-1
C. BURN AND BODILY INJURY PREVENTION	1-2
D. FIRE AND EXPLOSION PREVENTION	1-2
E. ARCING AND BURNING OF CONNECTOR	1-2
F. MEDICAL AND FIRST AID TREATMENT	1-2
G. EQUIPMENT WARNING LABELS	1-2
INTRODUCTION	2
A. HOW TO USE THIS MANUAL	2-1
B. EQUIPMENT IDENTIFICATION	2-1
C. RECEIPT OF EQUIPMENT	2-1
INITIAL SET-UP & DESCRIPTION	3
A. DIP SWITCH SELECTION	3-1
B. DESCRIPTION	3-1
LOCATION DIAGRAM	4
INSTALLATION	5
A. LOCATION	5-1
B. SAFETY	5-1
C. GROUNDING	5-1
D. ELECTRICAL INPUT REQUIREMENTS	5-1
E. AC INPUT VOLTAGE CHANGEOVER	5-1
F. CHARGING CABLE CONNECTORS	5-2
G. CONNECTION TO AC POWER	5-2
OPERATION	6
A. PRELIMINARY	6-1
B. NORMAL OR DAILY CHARGE	6-1
C. EQUALIZE OR WEEKEND CHARGE	6-2
D. MANUAL STOP	6-2
E. REFRESH CHARGE	6-2
F. BACK-UP TIMER SHUTDOWN	6-2
G. BATTERY DISCONNECT SHUTDOWN	6-2
H. AC POWER FAIL	6-2
I. 6-HOUR TERMINATION OPTION	6-3
J. ON-BOARD UTILITY OPTION	6-3
MAINTENANCE	7
SERVICE	8
TROUBLESHOOTING	9

BATTERY CHARGING QUESTIONS AND ANSWERS	10
PARTS LIST	11
DIAGRAMS	
WARRANTY	

SAFETY INSTRUCTIONS AND WARNINGS

FOR OPERATION OF BATTERY CHARGING EQUIPMENT

IMPORTANT – READ AND UNDERSTAND THESE INSTRUCTIONS. DO NOT LOSE THEM. ALSO READ OPERATING/INSTRUCTION MANUAL BEFORE INSTALLING, OPERATING, OR SERVICING THIS EQUIPMENT.

A. General

Battery charging products can cause serious injury or death, or damage to other equipment or property, if the operator does not strictly observe all safety rules and take precautionary actions.

Safe practices have developed from past experience in the use of charging equipment. These practices must be learned through study and training before using this equipment. Anyone not having extensive training in battery charging practices should be taught by experienced operators.

Only qualified personnel should install, use, or service this equipment.

B. Shock Prevention

Bare conductors, or terminals in the output circuit, or ungrounded, electrically-live equipment can fatally shock a person. To protect against shock, have competent electrician verify that the equipment is adequately grounded and learn what terminals and parts are electrically HOT.

The body's electrical resistance is decreased when wet, permitting dangerous current to flow through the body. Do not work in damp area without being extremely careful. Stand on dry rubber mat or dry wood and use insulating gloves when dampness or sweat cannot be avoided. Keep clothing dry.

1. Installation and Grounding of Electrically Powered Equipment – Electrical equipment must be installed and maintained in accordance with the National

Electrical Code, NFPA 70, and local codes. A power disconnect switch must be located at the equipment. Check nameplate for voltage and phase requirements. If only 3-phase power is available, connect *single-phase* equipment to only two wires of the 3-phase line. DO NOT CONNECT the equipment grounding conductor (lead) to the third live wire of the 3-phase line as this makes the equipment frame electrically HOT, which can cause a fatal shock.

Caution, To reduce the risk of fire, use only on circuits provided with the branch circuit protection in accordance with the National Electric Code, ANSI/NFPA 70.

If a grounding lead (conductor) is part of the power supply cable, be sure to connect it to a properly grounded switch box or building ground. If not part of the supply cable, use a separate grounding lead (conductor). Do not remove a ground prong from any plug. Use correct mating receptacles. Check ground for electrical continuity before using equipment.

The grounding conductor must be of a size equal to or larger than the size recommended by Code or in this manual.

2. Charging Leads – Inspect leads often for damage to the insulation. Replace or repair cracked or worn leads immediately. Use leads having sufficient capacity to carry the operating current without overheating.
3. Battery Terminals – Do not touch battery terminals while equipment is operating.
4. Service and Maintenance – Shut OFF all power at the disconnect switch or line breaker *before* inspecting, adjusting, or servicing the equipment. Lock switch OPEN (or remove line fuses) so that the power cannot be turned ON accidentally. Disconnect power to equipment if it is to be left unattended or out of service.

Disconnect battery from charger. Measure voltage on capacitors and discharge through an insulated screwdriver if there is any voltage reading.

Keep inside parts clean and dry. Dirt and/or moisture can cause insulation failure. This failure can result in high voltage at the charger output.

C. Burn And Bodily Injury Prevention

The battery produces very high currents when short circuited, and will burn the skin severely if in contact with any metal conductor that is carrying this current. Do not permit rings on fingers to come in contact with battery terminals or the cell connectors on top of the battery.

Battery acid is very corrosive. Always wear correct eye and body protection when near batteries.

D. Fire And Explosion Prevention

Batteries give off explosive flammable gases which easily ignite when coming in contact with an open flame or spark. Do not smoke, cause sparking, or use open flame near batteries. Charge batteries only in locations which are clean, dry, and well ventilated. Do not lay tools or anything that is metallic on top of any battery. All repairs to a battery must be made only by experienced and qualified personnel.

E. Arcing And Burning Of Connector

To prevent arcing and burning of the connector contacts, be sure the charger is OFF before connecting or disconnecting the battery. (If the charger is equipped with an ammeter, the ammeter should not indicate current flow.) Always connect battery before turning charger ON.

F. Medical And First Aid Treatment

First aid facilities and a qualified first aid person should be available for each shift for immediate treatment of electrical shock victims.

EMERGENCY FIRST AID: Call physician and ambulance immediately. Use First Aid techniques recommended by the American Red Cross.

DANGER: ELECTRICAL SHOCK CAN BE FATAL. If person is unconscious and electric shock is suspected, do not touch person if he or she is in contact with charging leads, charging equipment, or other live electrical parts. Disconnect (open) power at wall switch and then use First Aid. Dry wood, wooden broom, and other insulating material can be used to move cables, if necessary, away from person. IF BREATHING IS DIFFICULT, give oxygen. IF NOT BREATHING, BEGIN ARTIFICIAL BREATHING, such as mouth-to-mouth. IF PULSE IS ABSENT, BEGIN ARTIFICIAL CIRCULATION, such as external heart massage.

IN CASE OF ACID IN THE EYES, flush very well with clean water and obtain professional medical attention immediately.

G. Equipment Warning Labels

Inspect all precautionary labels on the equipment. Order and replace all labels that cannot be easily read.

INTRODUCTION

A. How To Use This Manual

To ensure safe operation, read the entire manual, including the chapter on safety instructions and warning.

IMPORTANT: It is especially important that all charger internal components be kept clean and dry, and all electrical connections tightened. Replace any precautionary or instruction label that cannot be easily read.

Throughout this manual, the words **WARNING**, **CAUTION**, and **NOTE** may appear. Pay particular attention to the information provided under these headings. These special annotations are easily recognized as follows:

WARNING gives information regarding possible personal injury. Warnings will be enclosed in a box such as this.

CAUTION refers to possible equipment damage. Cautions will be shown in bold

type.

NOTE offers helpful information concerning certain operating procedures. Notes will be shown in italics.

B. Equipment Identification

The unit's identification number (specification, model, serial number) usually appears on a data plate on the front (or rear) of the charger.

C. Receipt Of Equipment

When you receive the equipment, check it against the invoice to make sure it is complete and inspect the equipment for possible damage due to shipping. If there is any damage, notify the carrier immediately to file a claim. Furnish complete information concerning damage claims or shipping errors to the company shown on the cover of this manual. Include all equipment identification numbers and group part numbers (if any) as described above along with a full description of the parts in error.

This page intentionally left blank.

INITIAL SET-UP & DESCRIPTION

Set-Up

See Location Diagram of Selector Switches included in this manual.

For proper operation, the LTD Control must be set to match the charger in which it is installed.

Cell Size Selection

From the data plate on the charger, note the voltage output. Place the corresponding DIP switch (S1) on the LTD Control in the "Closed" position.

S1-1	12 Volts
S1-2	24 Volts
S1-3	36 Volts
S1-4	48 Volts
S1-5	Optional

Only one of the above DIP switches should be in the "Closed" position at any one time.

Auto Equalize

Switch S1-6 can be used to select either Auto Equalize or Manual Equalize.

S1-6	Equalize Type
Open	Auto Equalize every 5th Cycle.
Closed	Manual Equalize

Termination Type

Switch S1-7 can be used to select either dv/dt charge Termination or VT.

S1-7	80% Charged Voltage
Open	dV/dT
Closed	VT

6-Hour Termination Type

Switch S1-8 can be used to select the 6-Hour charge after 80% Termination.

S1-8	6-Hour Termination after 80%
Open	Off
Closed	On

Description

The LTD Control has an on board microcontroller to monitor and control the charging process. The up-to-date status of the charge cycle can be easily monitored by watching the status of the four LED's, charge in progress, 80% charged, charge complete, and equalize. The LTD Control utilizes either a Voltage/Time (VT) charge termination or a patented pt/dV/dT charge termination technique which eliminates excessive gassing by returning approximately 107% of the amp-hours removed from the battery. All front panel information (including operating instructions) is back printed on a polycarbonate overlay which is resistant to damage from oils, gasoline, and frequent operator handling. The LTD Control is "matched" to the output voltage of the charger by means of a printed circuit board mounted DIP switch. Features of the LTD Control include Auto start/stop, Auto/manual equalize, Manual Stop, Backup timer protection, Two charge termination methods, 2.37 V/C 80% point, 48 Hour Refresh, and AC power fail recovery.

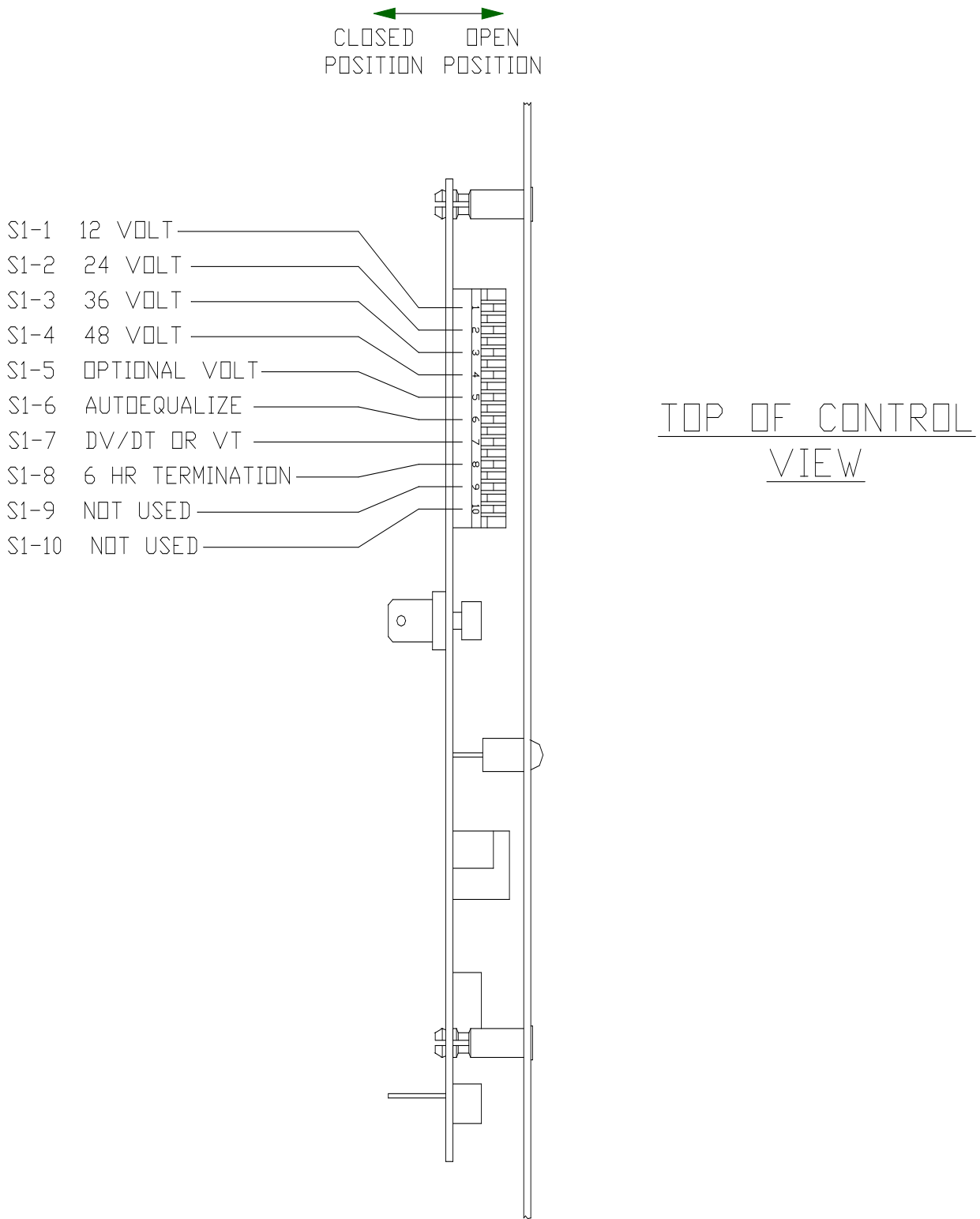

INSTALLATION

A. Location

FIRE HAZARD – As with any electrical power equipment, do not install on or over combustible materials. Keep charging area clear of combustible materials.

The charger must be installed indoors. Avoid locations exposed to high humidity, dust or ambient temperatures above 40°C. (104°F.)

Adequate air circulation is required to insure proper operation and long life. A minimum of 6 inches of free air space should be provided at both sides and rear of cabinet.

B. Safety

Refer to additional installation instructions under the SAFETY INSTRUCTIONS AND WARNINGS chapter included in this manual.

C. Grounding

The charger is provided with a 3 prong, grounding type plug on the AC input cord. The plug must only be used with a properly installed and grounded mating receptacle to insure user safety. It is the responsibility of the user to provide such a receptacle and that its installation meets all appropriate electrical codes.

D. Electrical Input Requirements

The AC input voltage and line draw is provided on a data plate located on the front (or rear) of the charger. The charger is provided with the proper AC cord and plug. Connect the AC input plug to an appropriate receptacle that is properly grounded and protected for 15 amperes (by a branch circuit fuse (s) or circuit breaker) (20 amperes for model 400-18). It is strongly recommended that the charger be the only equipment plugged into the branch supply circuit.

NOTE: Nuisance opening of branch circuit fuses or circuit breaker may result if equipment other than the charger is connected to the branch circuit.

E. AC Input Voltage Changeover

120 VOLTS AC INPUT MODELS

No AC input voltage changeover is required.

208/240 & 220/380 VAC INPUT MODELS

All 208/240 & 220/380 volts AC input models are shipped connected for a 240 or 380 volts AC input service respectively. For 208 or 220 volts AC input service, the charger must be reconnected as follows:

WARNING: ELECTRICAL SHOCK CAN BE FATAL! Be sure charger is unplugged from AC input power and battery is disconnected from charger before proceeding.

1. Remove the one piece top and sides.
2. Locate the terminal block (TB1) mounted on top of the ferroresonant power transformer.
3. Move the black wire from TB1, terminal 9 to TB1, terminal 8. Be sure the female terminal on the black wire is fully seated on the terminal block tab. See Figure 4-1.

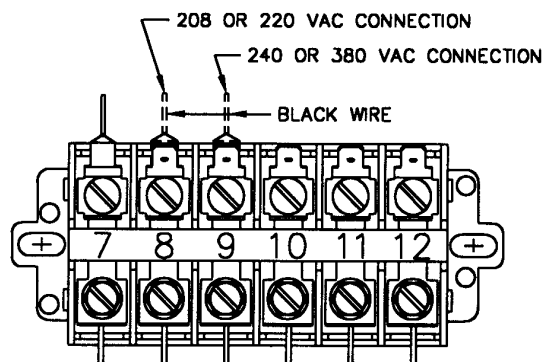

Figure 4-1 – TB1
AC Input Voltage Changeover

4. Replace the one piece top and sides.

CAUTION: Use of the charger with the voltage changeover set to the incorrect service voltage may result in dramatically reduced performance and life of the charger and/or battery.

If you don't know your service voltage, consult a qualified electrician.

F. Charging Cable Connectors

If connectors are already attached to the charging cables, make sure that they are attached so the charger positive polarity will connect to the positive terminal of the battery.

NOTE: The polarity of the charging cables on the charger are color coded. The red cable is positive and the black cable is negative.

If connectors must be attached to charging cables, follow instructions supplied with connectors.

CAUTION: Improper connections will "blow" charger output fuse and may cause other damage. Loose connections will reduce charger performance. Be certain the charger's positive charging cable will connect to the positive terminal of the battery. Make sure connectors are securely attached to cables (good solder connections, well tightened set screws or proper crimp, whichever is applicable.)

G. Connection To AC Power

After reading and following the installation instructions above, plug the charger AC input plug into the AC power receptacle.

OPERATION

A. Preliminary

Make sure the charger is installed and grounded as instructed in the INSTALLATION chapter of this manual.

Maintain electrolyte level in the batteries to be charged, as instructed by the battery manufacturer. Because the volume of electrolyte expands during the charging process, only add water when the battery is at least 80% charged. An amber light will be illuminated on the charger control panel when the battery is at or above 80% charge.

Insure the battery size matches the charger.

Battery number of cells must equal the number of cells stated on the charger data plate.

Battery ampere-hour capacity must be within the ampere-hour range stated on the charger data plate.

WARNING: EXPLOSION HAZARD – Do not connect a battery to this charger if the “Charge in Progress” LED is illuminated on the charger. Do not disconnect a battery from this charger if the “Charge in Progress” LED is illuminated or ammeter is indicating charging current; otherwise, arcing and burning of connector parts can occur or a battery explosion may result. Batteries produce explosive gases. Keep sparks, flames, and cigarettes away. Ventilate when charging in an enclosed area. Always shield eyes using face shield and goggles when working near batteries.

CAUTION: The charging of a battery with the incorrect number of cells or an ampere-hour capacity outside the range stated on the charger data plate will result in severe over or under charging of the battery, resulting in reduced battery performance and life.

B. Normal or Daily Charge

WARNING: DO NOT connect a battery to this charger if the “Charge in Progress” LED is lit. Do not disconnect a battery from this charger while a charge is in progress; otherwise, arcing and burning of connector parts or a battery explosion may result. Batteries produce explosive gases. Keep sparks, flame, and cigarettes away. Ventilate when charging in an enclosed area. Always shield eyes when working near batteries.

1. Insure the battery size matches the charger (Battery voltage and ampere hour capacity are within nameplate information).
2. Securely engage the battery and charger connectors.
3. After a five second delay (all LED's will be lit), the charger will turn on. The “Charge in Progress” LED will indicate charging current.
4. The “80% CHARGED” LED will light when the battery on charge reaches the 80% charged voltage.
5. The charger will automatically turn off and the “Charge Complete” LED will light when the charge has finished. reaching 80% charge. The light will remain on until the battery is disconnected from the charger.

NOTE: To disconnect battery from charger before charge is complete, first press the “Manual Stop” key, then disconnect the battery from the charger.

C. Equalize Or Weekend Charge

The LTD features Auto Equalize on every 5th charge cycle. Closing S1-6 can disable the feature. When the Auto Equalize feature is disabled, an Equalize charge can be selected or de-selected for any charge cycle using the sequence below.

1. Insure the battery size matches the charger. (Number of cells and ampere-hour capacity are within charger nameplate rating.)
2. Securely engage the battery and charger connectors.
3. After a 5 second delay (all LED's will be lit), the charger will turn on. The "Charge in Progress" LED will indicate charging current.
4. Press the "EQUALIZE" key. The "Equalize" LED will light solid. Press the key again to cancel the equalize charge.

NOTE: The equalize charge cannot be cancelled once the battery reaches the equalize charging period. Press the STOP key to terminate the charge.

5. The "80% CHARGED" LED will light when the battery on charge reaches the 80% charged voltage.
6. The battery reaches the normal termination point (dV/dT or VT). However, the battery is charged another 3 hours. The "Equalize" LED will flash during this equalize period.
7. The charger will automatically turn off, and the "Charge Complete" and the "Equalize" LED will light when the equalized charge has finished. The LEDs will remain on until the battery is disconnected from the charger.

WARNING: DO NOT connect a battery to this charger if the "Charge in Progress" LED is lit. Do not disconnect a battery from this charger while a charge is in progress; otherwise, arcing and burning of connector parts or a battery explosion may result. Batteries produce explosive gases. Keep sparks, flame, and cigarettes away. Ventilate when charging in an enclosed area. Always shield eyes when working near batteries.

D. Manual Stop

1. To turn the charger OFF during any part of a

charge cycle, press the STOP key. All four LEDs will flash.

2. To restart the charger, disconnect and reconnect the battery. A new charge cycle will begin.

E. Refresh Charge

In order to guarantee that a fully charged battery is always ready for use, a "Refresh" feature has been incorporated into the LTD Control. If a battery is left connected to the charger for 48 hours after a "Charge Complete" has been reached, the LTD will start a charge sequence. The running time of this "Refresh" charge will depend on the depth of self-discharge of the battery.

F. Back-up Timer Shutdown

A back-up timer will shut down the charger and all 4 LEDs will flash then the "Charge Complete" LED will flash if the battery on charge does not reach the 80% voltage during the first 13 hours of charging.

Likewise, if the LTD Control is set to terminate via the dV/dT methodology (DIP switch S1-7 off) and the charger does not reach the termination point within 5 hours after reaching the 80% charged voltage, all 4 LEDs will flash then the "Charge Complete" LED will flash.

G. Battery Disconnect Shutdown

If the battery is disconnected from the charger during a charge cycle, the charger will be shut down. All LEDs will be off.

H. AC Power Failure

During an AC power failure, the LTD Control stores key information about the charge cycle. The information is retained by powering some of the control's key components with a battery derived power supply. This causes the control to resume the charge where it left off when the AC power is returned, unaffected timers and equalize requests.

I. 6-Hour Termination Option

The control will leave the factory with the 6-Hour Termination Option disabled. The 6-Hour Termination Option when enabled overrides the previously selected termination types and auto equalize features. When dipswitch S1-8 is closed, the charger will always force a VT charge termination with an Equalize charge cycle. It is not suggested that this option be used for batteries that are cycled on a regular schedule; but for batteries that are seldom recharged and are commonly discharged below 100%.

J. On-Board Utility Option

The LTD Charger (194429 Control) with no additional modifications can be used in on-board applications where the output of the charger is always electrically connected to the battery on-board utility equipment (Pallet trucks, Golf carts, High-Low lifts, etc.). In this application, the truck operator would plug the AC input into a wall outlet when a charge cycle is required. The charger will automatically turn off when the battery is fully charged.

THIS PAGE INTENTIONALLY LEFT BLANK.

MAINTENANCE

WARNING: ELECTRIC SHOCK CAN BE FATAL – Before performing maintenance procedures, turn charger OFF and unplug from AC power, disconnect battery and check for voltage on capacitor (s). Discharge capacitor (s) with insulated screwdriver if there is any voltage present.

For uninterrupted, satisfactory service, it's necessary to keep the charger clean, dry, and well ventilated. At least every year, or more often if necessary, wipe and blow out all dirt from charger's interior components with clean, dry air of not over 25 psi (172 kPa). Use a hand bellows if compressed air is not available.

While charger cabinet is removed, check for broken wiring and damaged insulation on wiring. If any is observed, do not use charger until a qualified service person has repaired the charger.

Be sure all cabinet panels have been replaced before using charger.

This page intentionally left blank.

SERVICE

There are no user serviceable parts within the charger.

Refer all service needs to an authorized LTD Service Center. To avoid delays, have the charger specification no., model no., and serial no. available before contacting a Service Center. For the closest Service Center, write or call:

LTD Products

Troy, Ohio
45373

Phone 1-800-852-8689

This page intentionally left blank.

TROUBLESHOOTING

NOTE: If battery charger service is indicated, see the SERVICE chapter of this manual.

Troubleshooting Procedures

Charger will not turn ON (No LED check after the battery is connected to charger).

Charger has been connected to vehicle rather than battery.

Disconnect vehicle and connect battery to charger.

Broken charge cable or battery cable.

Have cable repaired or replaced by a qualified service person.

Broken battery or charger connection.

Have connector repaired or replaced by a qualified service person.

Defective charger control.

Have charger control replaced by an authorized service person.

Charger turns ON (“Charge In Progress” LED illuminates) but ammeter indicates no current.

Charger not plugged into AC power.

Plug charger into properly installed and grounded AC power receptacle.

Branch AC power circuit protection operated fuse (s) “blown” or circuit breaker tripped.

Replace fuse (s) with properly rated new fuse (s) or reset circuit breaker.

Battery number of cells greater than no. cells stated on charger data plate. (e.g.; A 12 cell battery has been connected to a 6 cell charger.)

Connect battery to properly sized charger.

Defective charger.

Have charger serviced by an authorized service person.

Charging current much less than DC Max Amps stamped on charger data plate.

Battery is nearly fully charged.

Charger is performing properly.

Charger set for wrong AC input service – 208/240 or 220/380 volts input models only – see AC input volts information on charger data plate.

Reconnect as described in the INSTALLATION chapter of this manual.

Battery is sulfated or has developed high resistance connection (s).

Have battery serviced by a qualified service person.

Defective charger.

Have charger serviced by an authorized service person.

Charging current much greater than DC Max Amps stamped on charger data plate.

Battery number of cells less than no. cells stated on charger data plate. (e.g.; A 6 cell battery has been connected to a 12 cell charger.

Connect battery to properly sized charger.

Charger set for wrong AC input service – 208/240 or 220/380 volts input models only – see AC input volts information on charger data plate.

Reconnect as described in the INSTALLATION chapter of this manual.

Battery is defective.

Have battery serviced by a qualified service person.

Branch AC power circuit protection operates repeatedly. (Fuse (s) “blow” or circuit breaker trips repeatedly.)

Branch circuit protection and/or wiring not rated for charger requirements as stated on charger data plate.

Have a qualified electrician review the branch circuit installation.

Branch circuit, circuit breaker defective.

Have a qualified electrician replace circuit breaker.

Defective charger.

Have charger serviced by an authorized service person.

Battery gasses or “boils” vigorously while charging.

Battery ampere-hour capacity is less than Amp Hour range stated on charger data plate.

Charge battery only with a properly matched charger.

Charger set for wrong AC input service – 208/240 or 220/380 volts input models only – see AC input volts information on charger data plate.

Reconnect as described in the INSTALLATION chapter of this manual.

Battery is defective.

Have battery serviced by a qualified service person.

AMBER 80% LED never illuminates during charge cycle and charger always runs for 13 hours.

Wrong DIP switch is selected.

Check DIP switches.

Battery ampere-hour capacity is greater than Amp. Hours range stated on charger data plate.

Charge battery only with a properly matched charger.

Charger set for wrong AC input service – 208/240 or 220/380 volts input models only – see AC input volts information on charger data plate.

Reconnect as described in the INSTALLATION chapter of this manual.

Battery is defective.

Have battery serviced by a qualified service person.

Battery fails to deliver expected performance or running time in vehicle.

Battery was put into vehicle before charge cycle was complete.

*Do **not** make a practice of using the battery before the charge cycle is complete.*

Battery ampere-hour capacity is greater than Amp. Hours range stated on charger data plate.

Charge battery only with a properly matched charger.

Battery is defective.

Have battery serviced by a qualified service person.

This page intentionally left blank.

BATTERY CHARGING QUESTIONS AND ANSWERS

1. How often should I charge my battery?

This is a very difficult question to answer as every application can be different. The health of the battery, the battery ampere-hour capacity and its relationship to the vehicle, the relationship of the battery ampere-hour capacity to the charger ampere-hour capacity, and the daily number of hours of vehicle use all influence how often the battery should be charged.

Many vehicles are equipped with “fuel” gauges and notify the operator when the battery should be charged. Fuel gauges typically suggest charging the battery when it is 80% discharged.

If the vehicle is not equipped with fuel gauge, most batteries are sized to a vehicle to provide approximately 6 hours of typical use. If you make continuous use of the vehicle all day long, then daily charging is recommended. If you use the vehicle 3 – 4 hours a day, then charging every other day makes sense. If the vehicle use is only occasional, then charging every weekend may be adequate.

If your vehicle use is sporadic and unpredictable, charge the battery when a decrease in vehicle performance is observed. A decrease in performance may be evidenced by slowing of forward speed, sluggish lifting of the forks or personnel lift, poor sweeping or a general slowing down of the battery powered equipment.

CAUTION: The proper charging of the battery is very important to obtaining expected battery life. Over-discharging and over/under-charging batteries are the leading causes of early battery failure. You have taken a good step in insuring battery life with the purchase of this charger. An excellent second step is to have a quality fuel gauge installed on the vehicle and use it. And finally, maintain the battery in accordance with the battery manufacturer’s recommendations.

2. How long should it take to charge my battery?

Again, this is a very difficult question to answer as every

application can be different. The relationship of the battery ampere-hour capacity to the charger ampere-hour capacity and the depth of discharge of the battery together dictate how long it will take to charge. It may take as little as three hours or as long as 14 hours.

CAUTION: The charging of a battery with an ampere-hour capacity outside the range stated on the charger data plate will result in severe over or under charging of the battery resulting in reduced battery performance and life.

3. How often should I equalize charge the battery?

During the normal charging and discharging process, the individual cells will get “out of step” with each other. A periodic equalize charge will bring all the cells back in step with each other. An equalize charge basically provides a forced overcharge to bring all cells up to a fully charged level. This charger provides an equalizing charge by running for 3 additional hours beyond a NORMAL charge cycle (when so instructed by pressing the EQUALIZE key).

If the battery manufacturer has not provided specific instructions regarding equalizing, it is recommended that it be performed after every fifth to tenth charge cycle. See also Item 1 above.

NOTE: Failure to perform an equalizing charge periodically may reduce the performance and life of the battery.

NOTE: Equalizing the battery every charge cycle will result in excessive water usage by the battery and may result in reduced battery life.

PARTS LIST

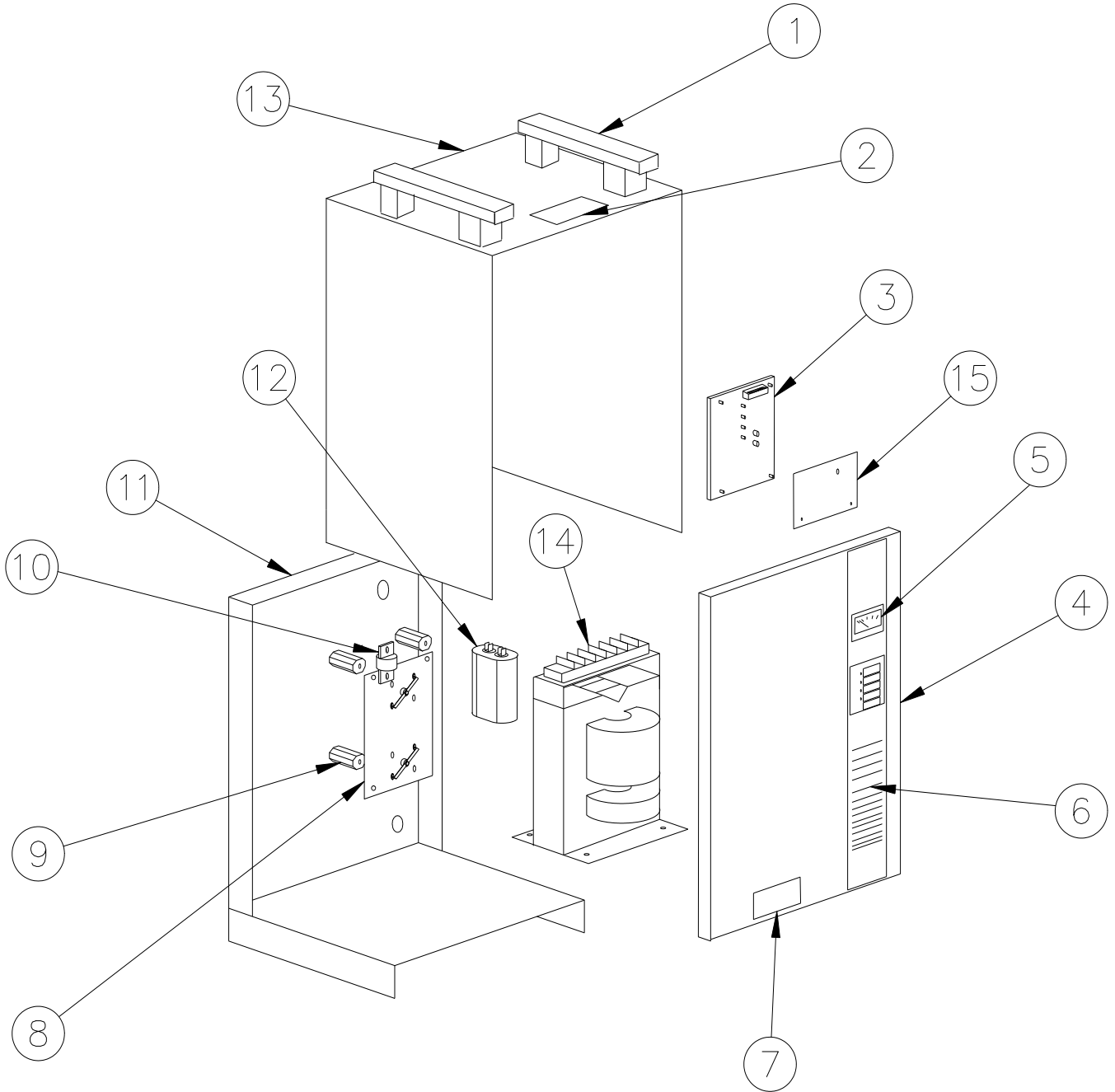

LTD BATTERY CHARGER

LTD FERRO-LINE
PARTS LIST

ITEM NO.	PART DESCRIPTION	QTY	COMMON TO ALL MODELS	FERRO 300-6	FERRO 510-6	FERRO 170-12	FERRO 300-12	FERRO 400-12	FERRO 510-12	FERRO 510-12 -240	FERRO 300-18	FERRO 400-18	FERRO 510-18	FERRO 250-24
1	HANDLE	2	409815											
2	DANGER LABEL	1	404099											
3	STD. CONTROL AY.	1	194429-1											
4	FRONT PANEL	1	194467											
5	AMMETER	1		409812-1	409812-2	409812-1	409812-1	409812-1	409812-2	409812-2	409812-1	409812-1	409812-2	409812-1
6	CONTROL LABEL	1		194559-1	194559-1	194559-2	194559-2	194559-2	194559-2	194559-2	194559-3	194559-3	194559-3	194559-4
7	WARNING LABEL	1	406434											
8	RECTIFIER AY	1	193899-1											
9	INSULATOR	3	404033											
10	DC OUTPUT FUSE	1		409023-3	409023-4	409023-3	409023-3	409023-3	409023-4	409023-4	409023-3	409023-3	409023-4	409023-3
11	BASE/REAR PANEL	1	194513											
12	CAPACITOR	1		TRY-154-6	TRY-154-2	TRY-154-6	TRY-154-2	TRY-154-2	TRY-154-6	TRY-154-6	TRY-154-6	TRY-154-6	TRY-154-6	TRY-154-6
13	TOP PANEL	1	191642											
14	TRANSFORMER	1		193120L	192997L	197880L	193000L	194157L	193003L	193005L	193021L	193018L	193015L	193117L
15	HIGH VOLTAGE INSULATOR	1	194536											
**	AC CORD & PLUG	1		409813-1	409813-1	409813-1	409813-1	409813-2	409813-1	409813-3	409813-1	409813-2	409813-3	409813-1
**	DC OUTPUT CABLE	1		396263-78	396263-79	396263-78	396263-78	396263-78	396263-79	396263-79	396263-78	396263-78	396263-79	396263-78

** Not Shown

This page intentionally left blank.

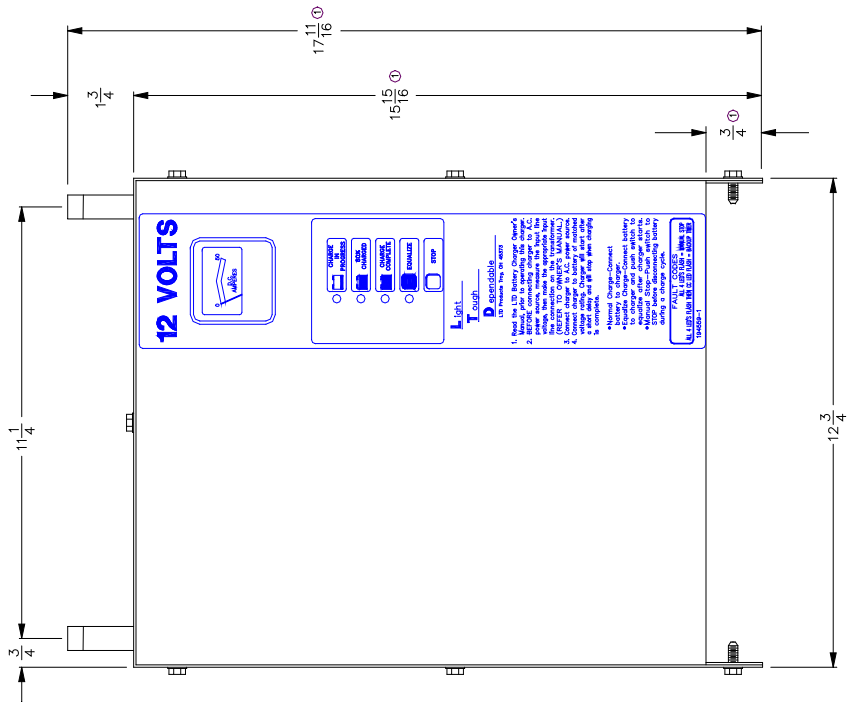

FRONT VIEW

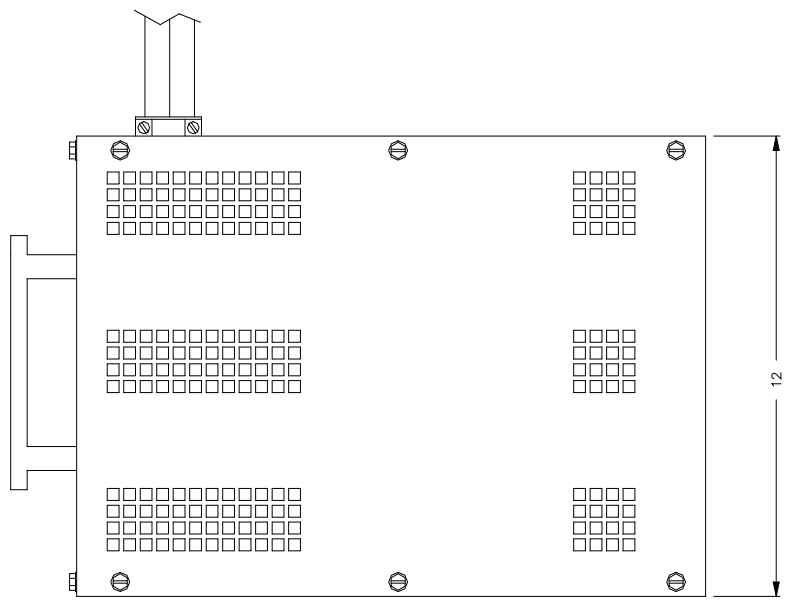

RIGHT SIDE VIEW

CHANGE RECORD E.C. NO.	DATE	FILE NAME	PLT DATE	FINISH CODE PER	ACTIVITY	REPLACED BY	REPLACES
		194598	4-11-00	193814	NONE		
UNLESS OTHERWISE SPECIFIED DIMENSIONS ARE IN INCHES/MILLIMETERS (INCHES ARE PRECEDENT). DIMENSIONS IN PARENTHESES ARE FOR INFORMATION ONLY. MATERIAL SPEC. QUANTITY-LUM. COMM. CLC.							
PRODUCTION PARTS AND ITEMS. PRODUCE TO RECORDED STANDARDS.							
TITLE: OUTLINE DIMENSIONAL							
UNIT: INCHES ± .010							
DECIMAL-INCH ANGLES ± .5°							
TOLERANCES UNLESS OTHERWISE SPECIFIED:							
FRACTIONS							
DRAWS							
SCALE							
DATE							
APPROVED							
DRAWN							
CHECKED							
DATE							
SCALE							
NONE							
FILE TYPE							
4-24-00							
SIZE							
SHEET							
DWC. NO.							
194598							
PROSOLITE POWER CORPORATION							
TROY, OHIO 45373, U.S.A.							

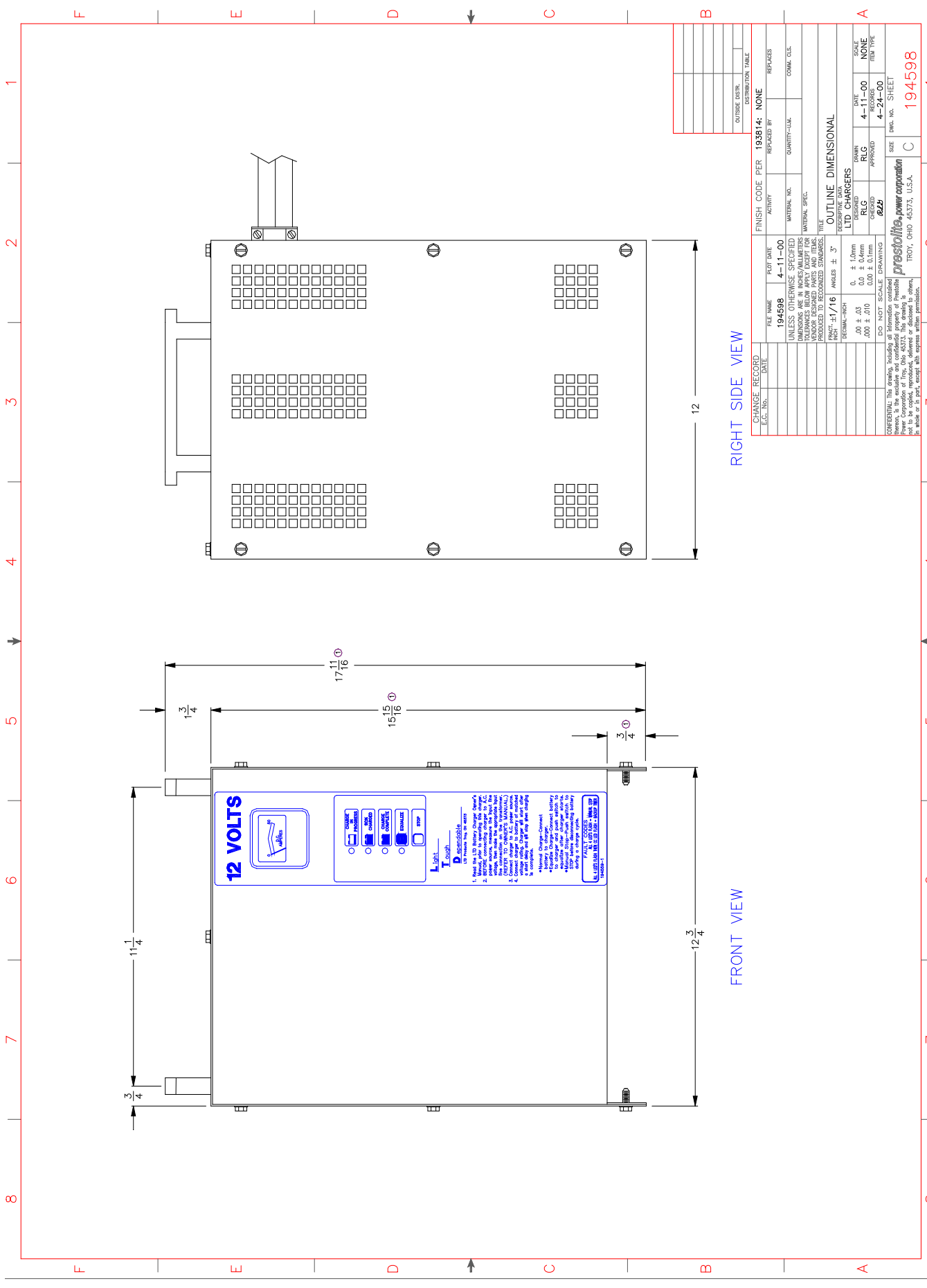

WARRANTY

LTD Light Industrial Battery Chargers

The manufacturer warrants that each new and unused LTD Battery Charger (the "Product") manufactured and supplied by it is of good workmanship and is free from any inherent mechanical defects, provided that:

- A. The Product is installed and operated in accordance with generally accepted industrial standards and in accordance with the enclosed printed instructions.
- B. The Product is used under normal conditions for which designed.
- C. The Product is not subjected to misuse, negligence or accident.
- D. The Product receives proper care, protection and maintenance under supervision of competent personnel.

The warranty is subject to the following conditions:

1. **TERMS OF WARRANTY.** Subject to the exceptions listed below the Product is warranted for one (1) year from date of shipment, provided that the Product is used in accordance with the manufacturer's published performance rating for the unit involved. During said period a product found to be defective will be repaired or replaced. Switch contacts, fuses, and bulbs are not warranted unless found to be defective prior to use. The exceptions to this warranty are as follows:

Ferroresonant power transformers and silicone diodes are warranted for three (3) years, provided however, that during the last two (2) years of this 3 year period the warranty covers parts replacement only – no labor, freight, or other services are provided by the manufacturer, nor shall the manufacturer be obligated to reimburse the owner or any other person for any work performed.

2. **PERSONS COVERED BY WARRANTY.** This warranty is extended by the manufacturer only to the purchaser of new Product from the manufacturer or one of its authorized distributors. The products purchased under this agreement shall be used exclusively by the purchaser and its employees and by no other persons, and therefore there shall be no third party beneficiary to this warranty.
3. **LIMITATION OF REMEDY.** The existence of claimed defects in any Product covered by this warranty is subject to authorized repair center inspection and judgement. The manufacturer's liability is limited to repair of any defects found by the authorized repair center to exist or, at the manufacturer's option, the replacement of the defective Product after the defective Product has been returned by the purchaser at its expense to an authorized repair center. Replacement and exchange parts will be warranted for the remainder of the original manufacturer Product Warranty, or for a period of ninety (90) days, whichever is greater.

THE MANUFACTURER AND ITS AUTHORIZED DISTRIBUTORS OR DEALERS SHALL NOT BE LIABLE FOR DIRECT OR INDIRECT, SPECIAL OR CONSEQUENTIAL DAMAGES, INCLUDING BUT NOT LIMITED TO, EXPENSES FOR TELEPHONE CALLS, TELEGRAMS, TRAVEL, LODGING, DUTIES AND TAXES, LABOR, RENTAL OR REPLACEMENT EQUIPMENT, LOSS OF BUSINESS OR PROFITS OR OTHER COMMERCIAL LOSSES.

4. **USE OF DEFECTIVE PRODUCT.** Continued use of the Product after discovery of a defect VOIDS ALL WARRANTIES.
5. **ALTERED EQUIPMENT.** Except as authorized in writing, the warranty specified does not cover any product that has been altered by any party other than the authorized repair center.

EXCEPT AS STATED ABOVE, ALL OTHER WARRANTIES AND CONDITIONS, WHETHER EXPRESSED OR IMPLIED, INCLUDING IMPLIED WARRANTIES OF MERCHANTABILITY AND FITNESS FOR A PARTICULAR PURPOSE, ARE EXCLUDED. To ensure safe operation, equipment must be installed and serviced by skilled, qualified personnel and in accordance with all federal, state, and local electrical codes. The manufacturer neither assumes nor authorizes any person(s) to assume for the manufacturer any other liability in connection with the sale or use of the goods sold, and there are no oral agreements or warranties collateral to or affecting this written warranty.

**AMETEK Prestolite Power
Troy, Ohio USA**

Data Sheet: 1540
Index: 060102
Replaces: 110100



